



General Description

Series D81VW directional control valves are 5-chamber, pilot operated, solenoid controlled valves. They are available in 2 or 3-position styles. These valves are manifold or subplate mounted, and conform to NFPA's D08, CETOP 8 mounting pattern.

Operation



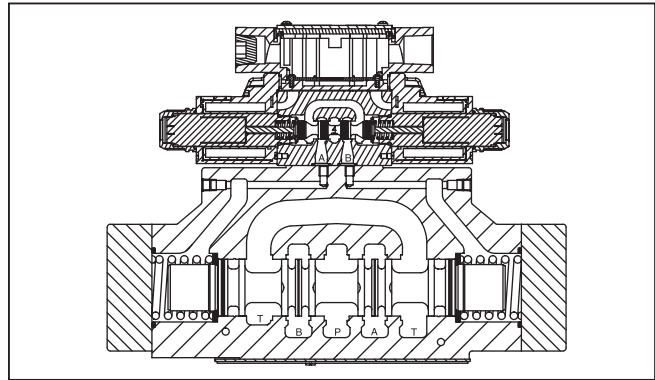
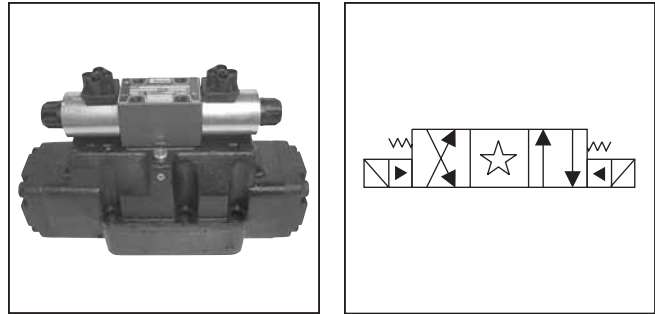

Series D81VW pilot operated valves are standard with low shock spools and pilot orifice. The orifice can be removed if a faster shift is required. It is recommended, however, that all systems operating above 138 Bar (2000 PSI) use the standard valve to avoid severe shock.

Features

- Low pressure drop design.
- Hardened spools provide long life.
- Fast response option available.
- Wide variety of voltages and electrical connection options.
- Explosion proof availability.
- No tools required for coil removal.



Specifications

Mounting Pattern	NFPA D08, CETOP 8, NG25
Maximum Operating Pressure	345 Bar (5000 PSI) Standard 207 Bar (3000 PSI) 10 Watt CSA  207 Bar (3000 PSI)
Maximum Tank Line Pressure	Internal Drain Model: 103 Bar (1500 PSI) AC Only 207 Bar (3000 PSI) DC Std., AC Optional External Drain Model: 345 Bar (5000 PSI) CSA  103 Bar (1500 PSI)
Maximum Drain Pressure	103 Bar (1500 PSI) AC Only 207 Bar (3000 PSI) DC Std., AC Optional CSA  103 Bar (1500 PSI)
Minimum Pilot Pressure	5.1 Bar* (75 PSI)
Maximum Pilot Pressure	345 Bar (5000 PSI) Standard CSA  207 Bar (3000 PSI)
Nominal Flow	302 LPM (80 GPM)

* 6.9 Bar (100 PSI) for spool configurations 002, 007, 008, 009 & 014.

Response Time

Response times (milliseconds) are measured at 345 Bar (5000 PSI) and 300 LPM (80 GPM) with various pilot pressures as indicated.

Solenoid Type	Pilot Pressure	Pull-In		Drop-Out	
		Std	Fast	Std	Fast
DC	500	140	100	70	70
	1000	125	90	76	76
	2000	100	70	70	70
AC	500	100	60	60	60
	1000	85	50	60	60
	2000	60	30	60	60

Because of the high drain line pressure transients generated during shifting, use of the fast response option is not recommended for pilot pressures exceeding 138 Bar (2000 PSI).

A

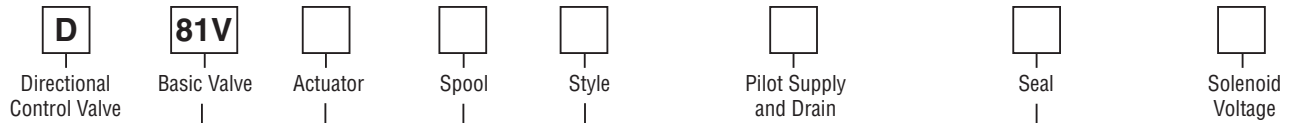

NFPA D08
 CETOP 8
 DIN NG25
 High Flow, D03 Pilot

Code	Description
W*	Solenoid, Wet Pin, Screw-in
HW*	Reversed Wiring

Code	Description
N	Nitrile
V	Fluorocarbon

Code	Description
1	Internal Pilot, External Drain
2	External Pilot, External Drain
3	Internal Pilot w/Check, External Drain
4*	Internal Pilot, Internal Drain
5	External Pilot, Internal Drain
6	Internal Pilot w/Check, Internal Drain

Code	Description
A*	24/50 VAC
D	120 VDC
G	198 VDC
J	24 VDC
K	12 VDC
N**	220/50 VAC
Q*	100/60 VAC
QD†	100 VAC/60 Hz 100 VAC/50 Hz
R	24/60 VAC
T	240/60 - 220/50 VAC
U	98 VDC
Y	120/60 - 110/50 VAC
Z	250 VDC

* Valve schematic symbols are per NFPA/ANSI standards, providing flow P to A when energizing solenoid A. Note operators reverse sides for #008 and #009 spools. See installation information for details. To configure per DIN standards (A coil over A port, B coil over B port) code valves as D81VHW***.

* Not available with 002, 007, 008, 009, 014 & 030 spools.

* High Watt Coil only.
 ** Explosion Proof only.
 † Available in DIN only.

Code	Symbol	Code	Symbol
001		012	
002		014	
003		015	
004		016	
005		020*	
006		030**	
007		081	
008*		082	
009**			
011			

* 008 & 020 spool have closed crossover.
 ** 009 & 030 spool have open crossover.

Code	Description	Symbol
B*	Single solenoid, 2 position, spring offset. P to A and B to T in offset position.	
C	Double solenoid, 3 position, spring centered.	
D*	Double solenoid, 2 position, detent.	
E	Single solenoid, 2 position, spring centered. P to B and A to T when energized.	
F**	Single solenoid, 2 position, spring offset, energized to center. Position spool spacer on A side. P to A and B to T in spring offset position.	
H*	Single solenoid, 2 position, spring offset. P to B and A to T in offset position.	
K	Single solenoid, 2 position, spring centered. P to A and B to T when energized.	
M**	Single solenoid, 2 position, spring offset, energized to center position. Spool spacer on B side. P to B and A to T in spring offset position.	

* Available with 020 and 030 spools only.
 ** High watt coil only.

Bold: Designates Tier I products and options.

Non-bold: Designates Tier II products and options. These products will have longer lead times.

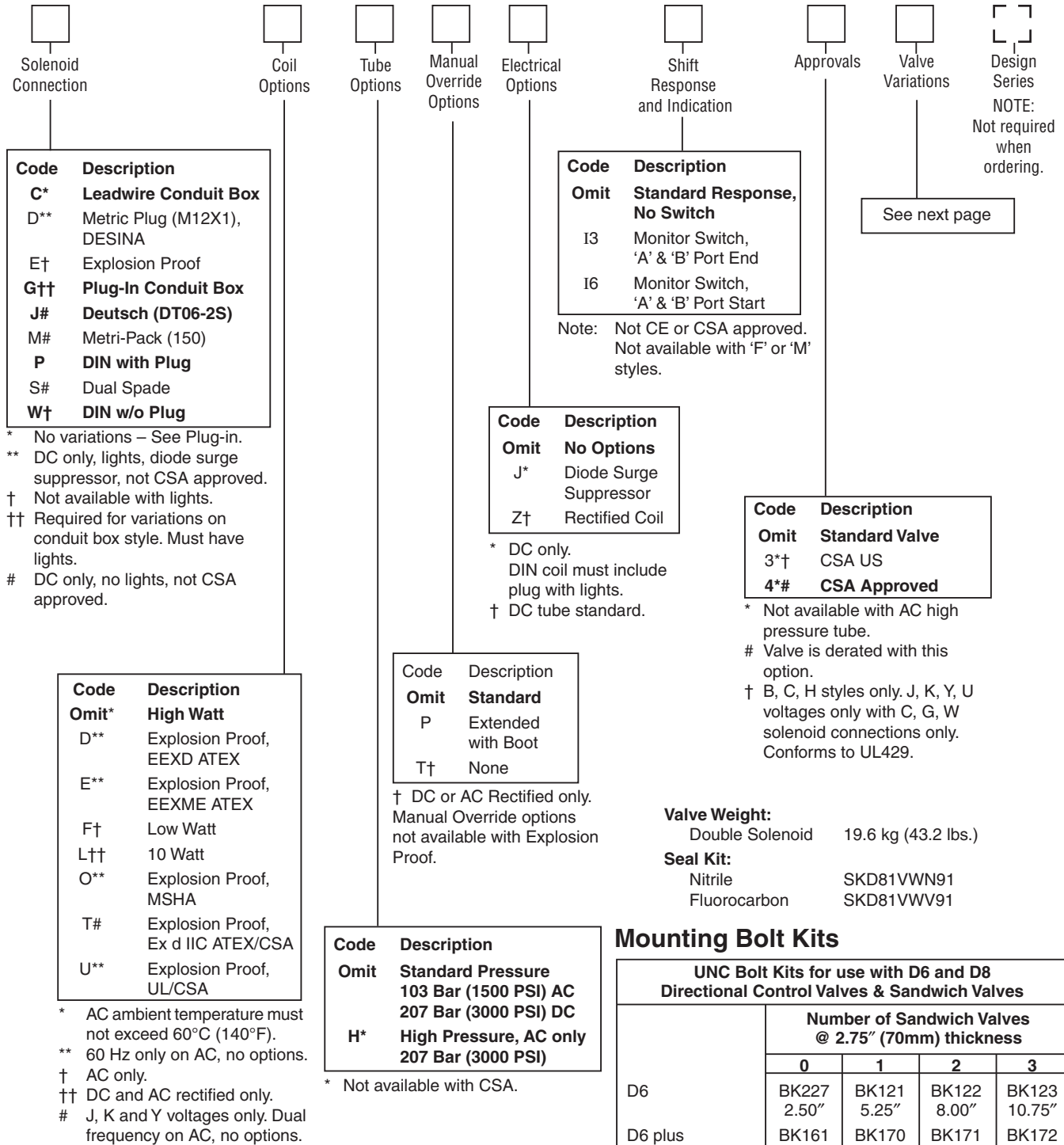

Valve Weight:
 Double Solenoid 19.6 kg (43.2 lbs.)

Seal Kit:
 Nitrile SKD81VWN91
 Fluorocarbon SKD81VWV91

Mounting Bolt Kits

UNC Bolt Kits for use with D6 and D8 Directional Control Valves & Sandwich Valves				
	Number of Sandwich Valves @ 2.75" (70mm) thickness			
	0	1	2	3
D6	BK227 2.50"	BK121 5.25"	BK122 8.00"	BK123 10.75"
D6 plus tapping plate	BK161 3.50"	BK170 6.25"	BK171 9.00"	BK172 11.75"
D8	BK228 3.00"	BK131 5.75"	BK132 8.50"	BK133 11.25"
D8 plus tapping plate	BK173 4.00"	BK174 6.75"	BK175 9.50"	BK114 12.125"

Note: All bolts are SAE grade 8, 1/2-13 UNC-3A thread, torque to 133 N.m. (100 ft.-lbs.)

Bold: Designates Tier I products and options.

Non-bold: Designates Tier II products and options. These products will have longer lead times.



Valve Variations

A

Code	Description
5*	Signal Lights – Standard
	Signal Lights – Hirsch. (DIN with Plug)
7B**	Manaplug – Brad Harrison (12x1) Micro with Lights
56**	Manaplug (Mini) with Lights
20	Fast Response
1C**	Manaplug (Mini) Single Sol. 5-pin, with Lights
1D**	Manaplug (Micro) Single Sol. 5-pin, with Lights
1G**	Manaplug (Mini) Single Sol. 5-pin, with Stroke Adjust 'A' & 'B' End and Lights
1H**	Manaplug (Micro) Single Sol. 5-pin, with Stroke Adjust 'A' & 'B' End and Lights
1M**	Manaplug Opposite Normal
1P	Painted Body
1R	Stroke Adjust 'A' & 'B' End with Pilot Choke Meter In
3A	Pilot Choke Meter Out
3B	Pilot Choke Meter In
3C	Pilot Pressure Reducer
3D	Stroke Adjust 'B' End
3E	Stroke Adjust 'A' End
3F	Stroke Adjust 'A' & 'B' End
3G*	Pilot Choke Meter Out with Lights
3H*	Pilot Choke Meter In with Lights
3J*	Pilot Pressure Reducer with Lights
3K	Pilot Choke Meter Out with Stroke Adjust 'A' & 'B' End
3L**	Pilot Choke Meter Out, Stroke Adjust 'A' & 'B' End with Lights and Manaplug — Brad Harrison Mini
3M	Pilot Choke Meter Out, Pilot Pressure Reducer, Stroke Adjust 'A' & 'B' End
3R	Pilot Choke Meter Out & Pilot Pressure Reducer
3S**	Lights, Mini Manaplug, Pilot Choke Meter Out
7Y**	M12x1 Manaplug (4-pin), Special Wiring, and Lights

* DESINA, plug-in conduit box, and DIN with plug styles only.

** Must have plug-in style conduit box.



Reference Data

Model	Spool Symbol	Maximum Flow, LPM (GPM) 345 Bar (5000 PSI) w/o Malfunction	Model	Spool Symbol	Maximum Flow, LPM (GPM) 345 Bar (5000 PSI) w/o Malfunction
D81V*001		624 (160)	D81V*008 D81V*009		312 (80)
D81V*002		624 (160)	D81V*011		624 (160)
D81V*003		624 (160)	D81V*012		312 (80)
D81V*004		624 (160)	D81V*014		312 (80)
D81V*005		624 (160)	D81V*015		624 (160)
D81V*006		624 (160)	D81V*016		624 (160)
D81V*007		312 (80)	D81V*020 D81V*030		624 (160)

D81V* Series Pressure Drop Chart

The following chart provides the flow vs. pressure drop curve reference for the Series D81V* valve by spool type.

VISCOSITY CORRECTION FACTOR							
Viscosity (SSU)	75	150	200	250	300	350	400
% of ΔP (Approx.)	93	111	119	126	132	137	141
Curves were generated using 100 SSU hydraulic oil. For any other viscosity, pressure drop will change as per chart.							

D81VW Pressure Drop Reference Chart – Curve Number					
Spool No.	P-A	P-B	P-T	A-T	B-T
001	1	1	–	3	4
002	2	2	5	4	6
003	1	1	–	4	4
004	1	1	–	4	6
005	2	2	–	3	4
006	2	2	–	3	4
007	1	2	8	3	6
009	2	2	7	3	4
011	1	1	–	3	4
012	1	1	9	3	4
014	2	1	8	6	3
015	2	2	–	5	5
016	2	2	–	4	3
020/030	2	2	–	3	4

Performance Curves

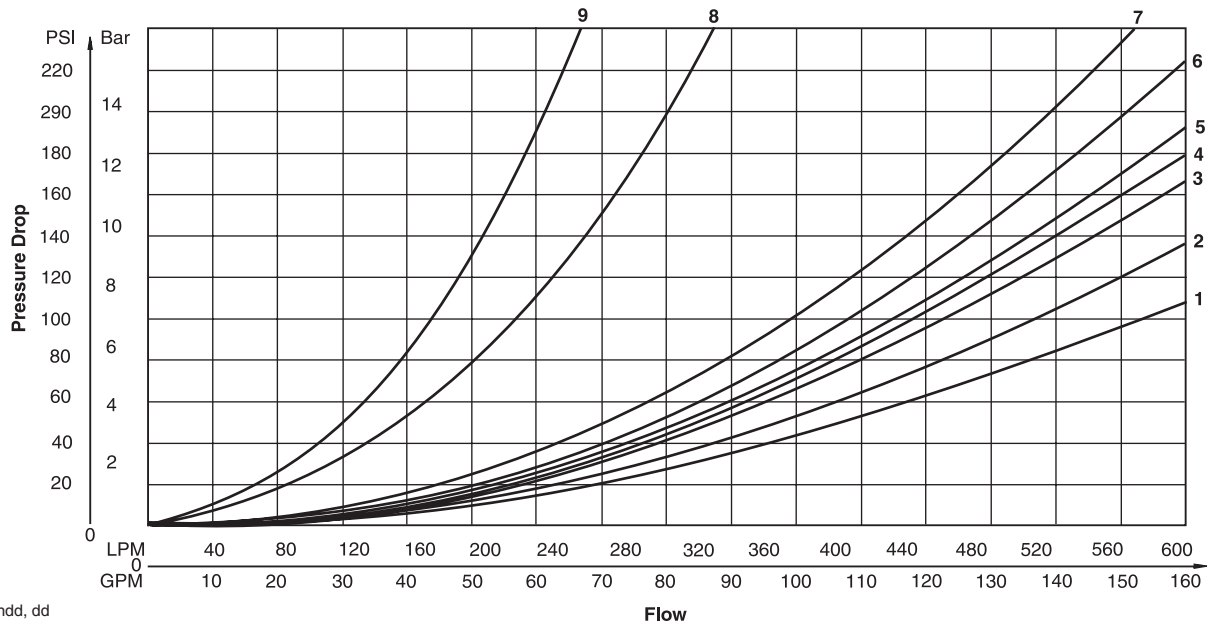

D81.indd, dd





Solenoid Ratings

Insulation System	Class F
Allowable Deviation from rated voltage	-15% to +10% for DC and AC rectified coils -5% to +5% for AC Coils
Armature	Wet pin type
CSA File Number	LR60407
Environmental Capability	DC Solenoids meet NEMA 4 and IP67 when properly wired and installed. Contact HVD for AC coil applications.

Explosion Proof Solenoid Ratings*

U.L. & CSA (EU)	Class I, Div 1 & 2, Groups C & D Class II, Div 1 & 2, Groups E, F & G As defined by the N.E.C.
MSHA (EO)	Complies with 30CFR, Part 18
ATEX (ED)	Complies with ATEX requirements for: Exd, Group IIB; EN50014: 1999+ Amds. 1 & 2, EN50018: 2000
ATEX & CSA/US (ET)	Complies with ATEX EN60079-0, EN60079-1 Ex d IIC; CSA/US Ex d IIC, AEx d IIC for Class I, Zone 1, UL1203, UL1604, CSA E61241,1 Class II, Div 1

* Allowable Voltage Deviation ±10%.
 Note that Explosion Proof AC coils are single frequency only.

Code		Voltage	In Rush Amps Amperage	In Rush VA	Holding Amps @ 3MM	Watts	Resistance
Voltage Code	Power Code						
D	L	120 VDC	N/A	N/A	0.09 Amps	10 W	1584.00 ohms
D	Omit	120 VDC	N/A	N/A	0.26 Amps	30 W	528.00 ohms
G	Omit	198 VDC	N/A	N/A	0.15 Amps	30 W	1306.80 ohms
J	L	24 VDC	N/A	N/A	0.44 Amps	10 W	51.89 ohms
J	Omit	24 VDC	N/A	N/A	1.32 Amps	30 W	17.27 ohms
K	L	12 VDC	N/A	N/A	0.88 Amps	10 W	12.97 ohms
K	Omit	12 VDC	N/A	N/A	2.64 Amps	30 W	4.32 ohms
L	L	6 VDC	N/A	N/A	1.67 Amps	10 W	3.59 ohms
L	Omit	6 VDC	N/A	N/A	5.00 Amps	30 W	1.20 ohms
Q	Omit	100 VAC / 60 Hz	2.05 Amps	170 VA	0.77 Amps	30 W	19.24 ohms
QD	F	100 VAC / 60 Hz	1.35 Amps	135 VA	0.41 Amps	18 W	31.20 ohms
QD	F	100 VAC / 50 Hz	1.50 Amps	150 VA	0.57 Amps	24 W	31.20 ohms
R	F	24/60 VAC, Low Watt	6.67 Amps	160 VA	2.20 Amps	23 W	1.52 ohms
T	Omit	240/60 VAC	0.83 Amps	199 VA	0.30 Amps	30 W	120.40 ohms
T	Omit	220/50 VAC	0.87 Amps	191 VA	0.34 Amps	30 W	120.40 ohms
T	F	240/60 VAC, Low Watt	0.70 Amps	168 VA	0.22 Amps	21 W	145.00 ohms
T	F	220/50 VAC, Low Watt	0.75 Amps	165 VA	0.26 Amps	23 W	145.00 ohms
U	L	98 VDC	N/A	N/A	0.10 Amps	10 W	960.00 ohms
U	Omit	98 VDC	N/A	N/A	0.31 Amps	30W	288.00 ohms
Y	Omit	120/60 VAC	1.7 Amps	204 VA	0.60 Amps	30 W	28.20 ohms
Y	Omit	110/50 VAC	1.7 Amps	187 VA	0.68 Amps	30 W	28.20 ohms
Y	F	120/60 VAC, Low Watt	1.40 Amps	168 VA	0.42 Amps	21 W	36.50 ohms
Y	F	110/50 VAC, Low Watt	1.50 Amps	165 VA	0.50 Amps	23 W	36.50 ohms
Z	L	250 VDC	N/A	N/A	0.04 Amps	10 W	6875.00 ohms
Z	Omit	250 VDC	N/A	N/A	0.13 Amps	30 W	1889.64 ohms
Explosion Proof Solenoids							
R		24/60 VAC	7.63 Amps	183 VA	2.85 Amps	27 W	1.99 ohms
T		240/60 VAC	0.76 Amps	183 VA	0.29 Amps	27 W	1.34 ohms
N		220/50 VAC	0.77 Amps	169 VA	0.31 Amps	27 W	1.38 ohms
Y		120/60 VAC	1.60 Amps	192 VA	0.58 Amps	27 W	33.50 ohms
P		110/50 VAC	1.47 Amps	162 VA	0.57 Amps	27 W	34.70 ohms
K		12 VDC	N/A	N/A	2.75 Amps	33 W	4.36 ohms
J		24 VDC	N/A	N/A	1.38 Amps	33 W	17.33 ohms
"ET" Explosion Proof Solenoids							
K		12 VDC	N/A	N/A	1.00 Amps	12 W	12.00 ohms
J		24 VDC	N/A	N/A	1.00 Amps	13 W	44.30 ohms
Y		120/60-50 VAC	N/A	N/A	0.16 Amps	17 W	667.00 ohms

D81.indd, dd



Inch equivalents for millimeter dimensions are shown in (**)

Plug-in Conduit Box, Double AC Solenoid

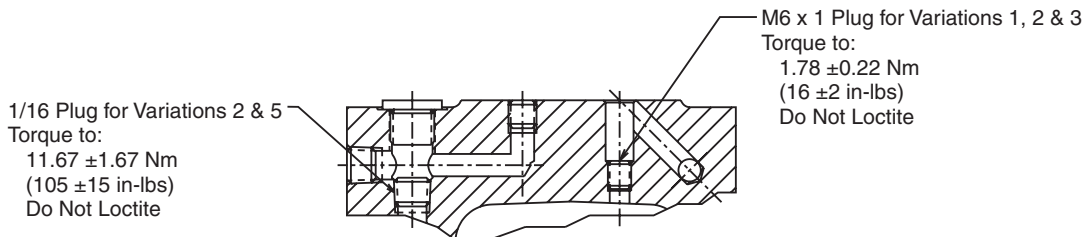
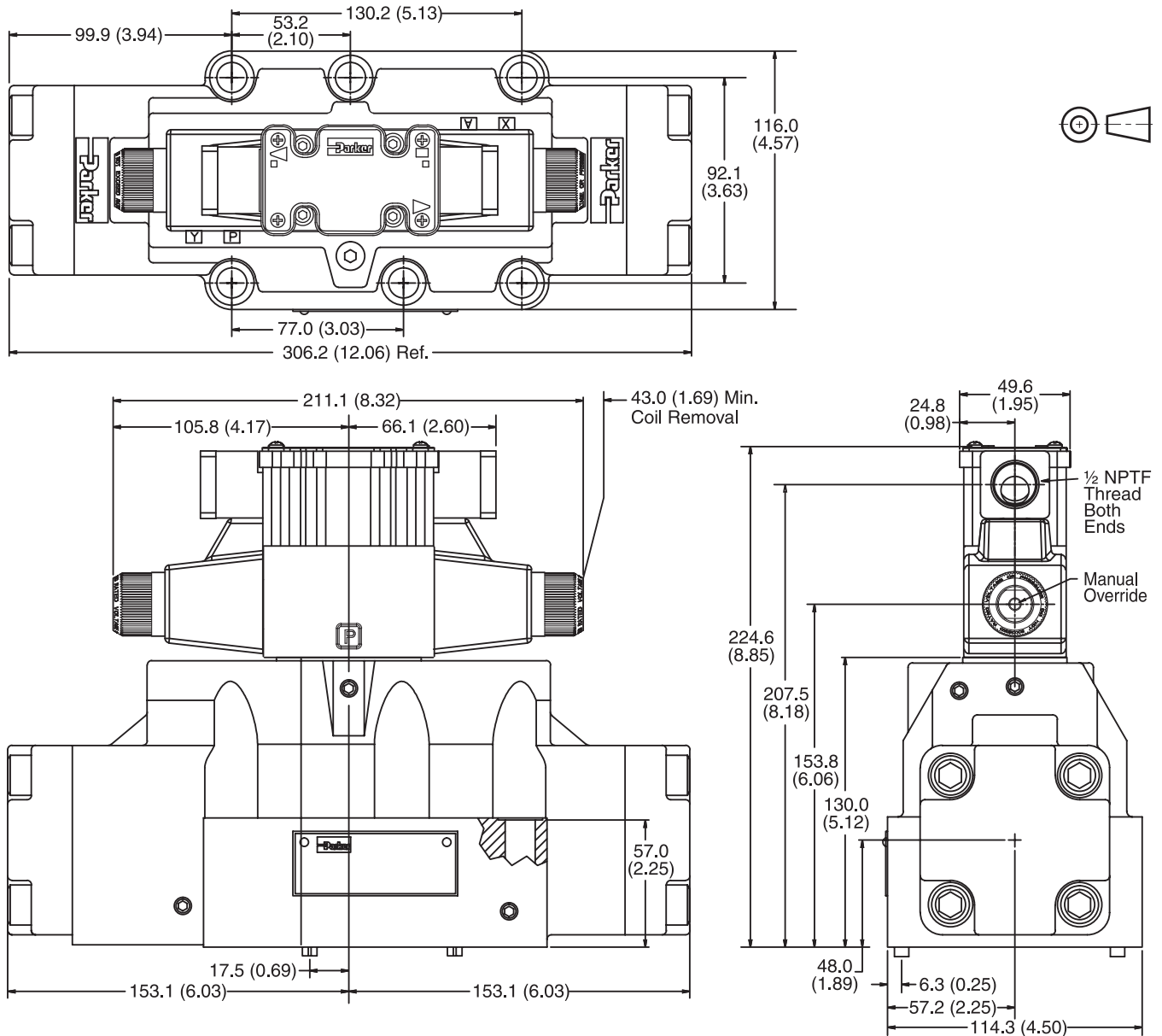

Note: 57mm (2.24") from bottom of bolt hole counterbore to bottom of valve.

Inch equivalents for millimeter dimensions are shown in (**)

A

Conduit Box and Stroke Adjust, Double AC Solenoid

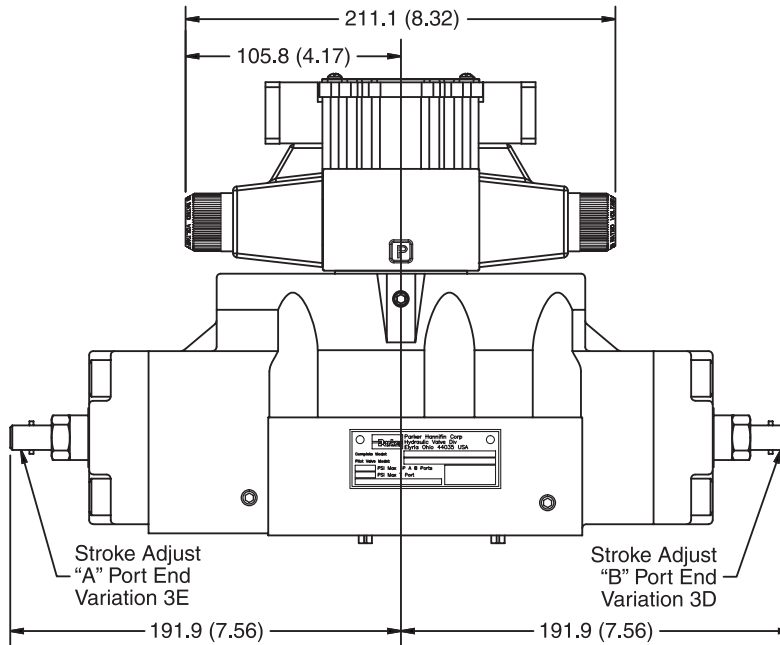

Note: 57mm (2.24") from bottom of bolt hole counterbore to bottom of valve.

Conduit Box and Pilot Choke Control, Double AC Solenoid

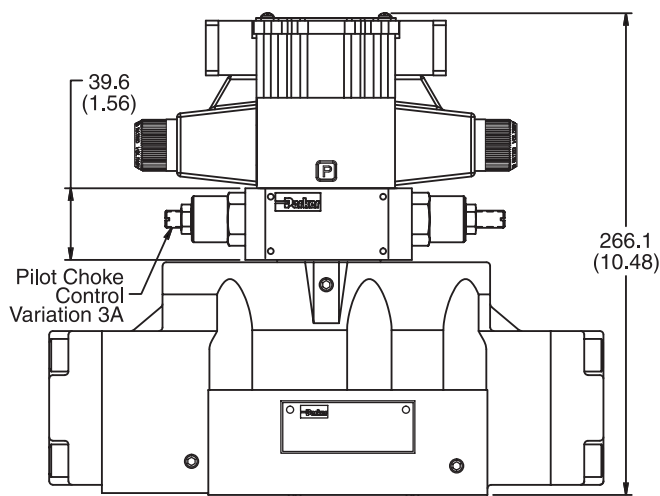

Conduit Box, Single AC Solenoid

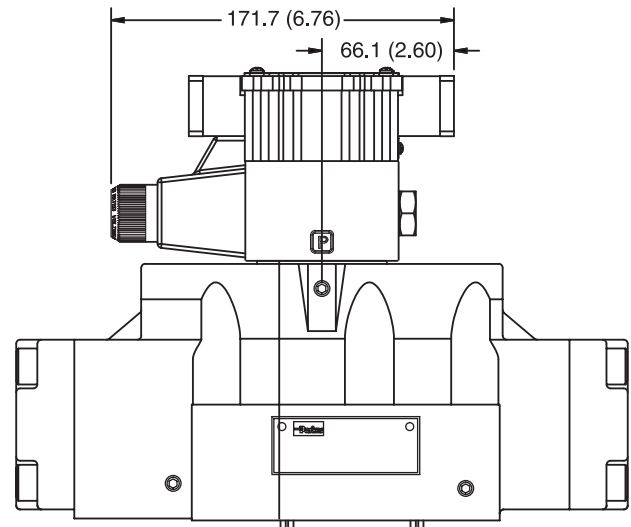

Inch equivalents for millimeter dimensions are shown in (**)

Plug-In Conduit Box, Double DC Solenoid

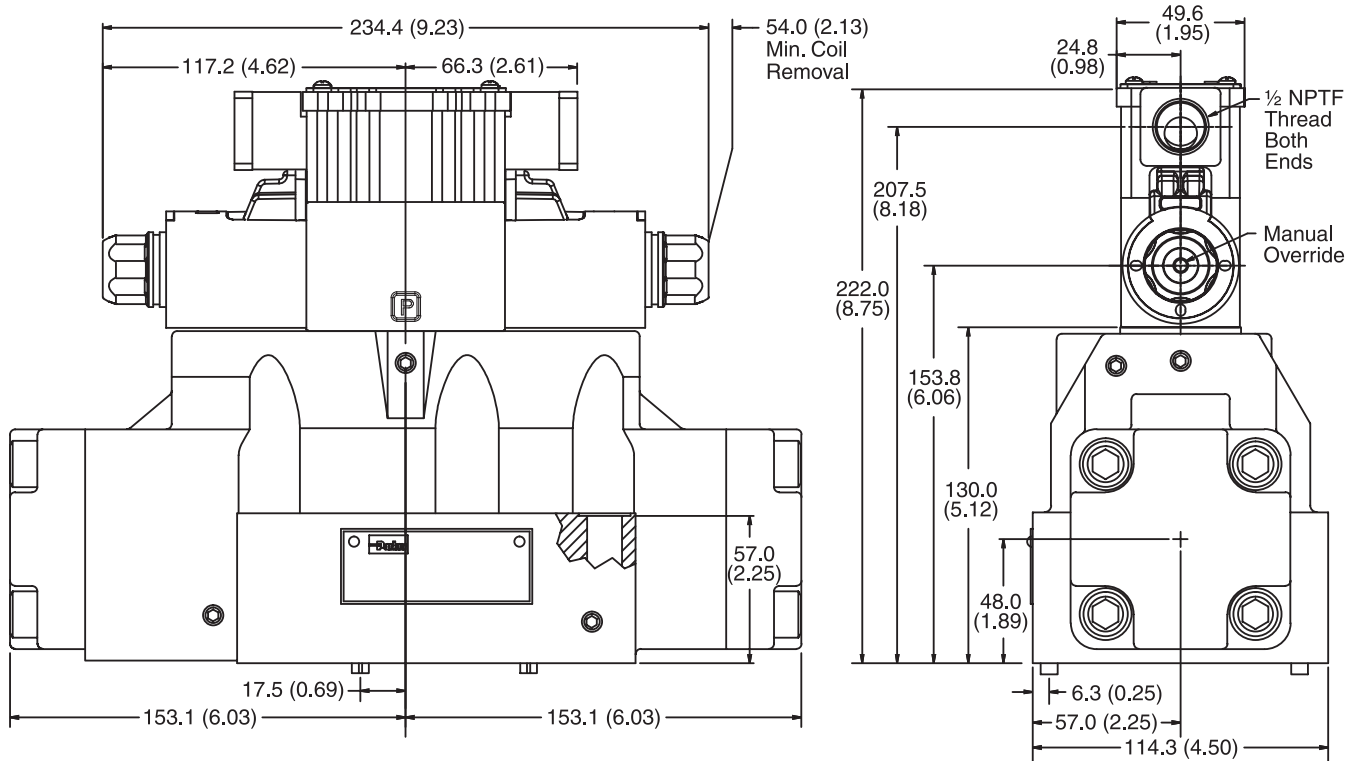
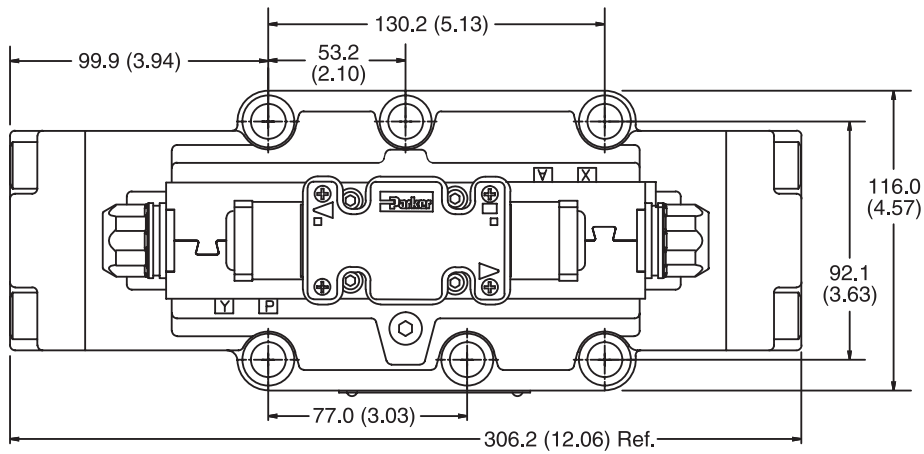

Note: 57mm (2.24") from bottom of bolt hole counterbore to bottom of valve.



Inch equivalents for millimeter dimensions are shown in (**)

A

Plug-In Conduit Box and Stroke Adjust, Double DC Solenoid

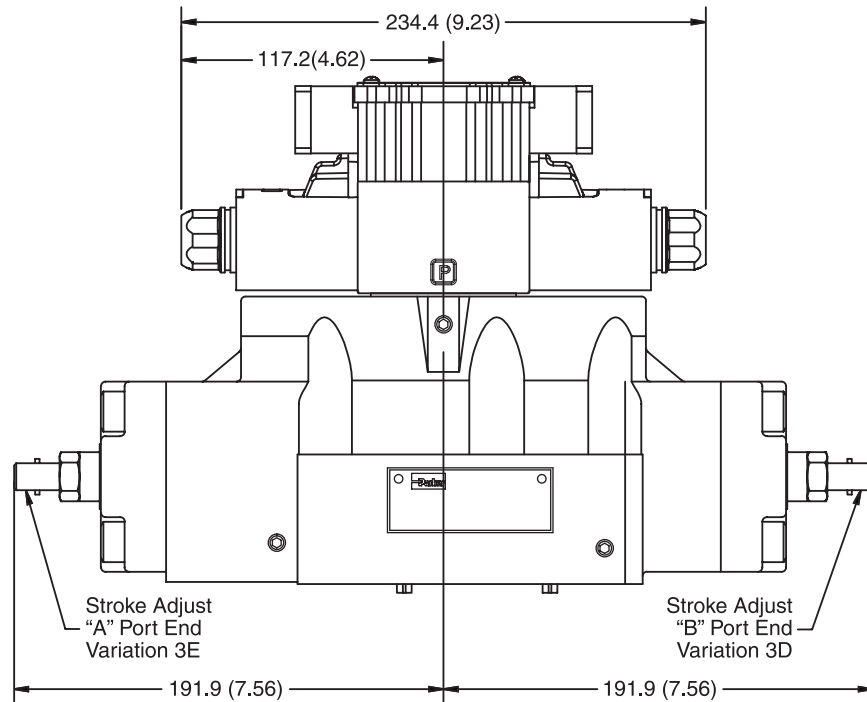

Note: 57mm (2.24") from bottom of bolt hole counterbore to bottom of valve.

Hirschmann and Pilot Choke Control, Double DC Solenoid

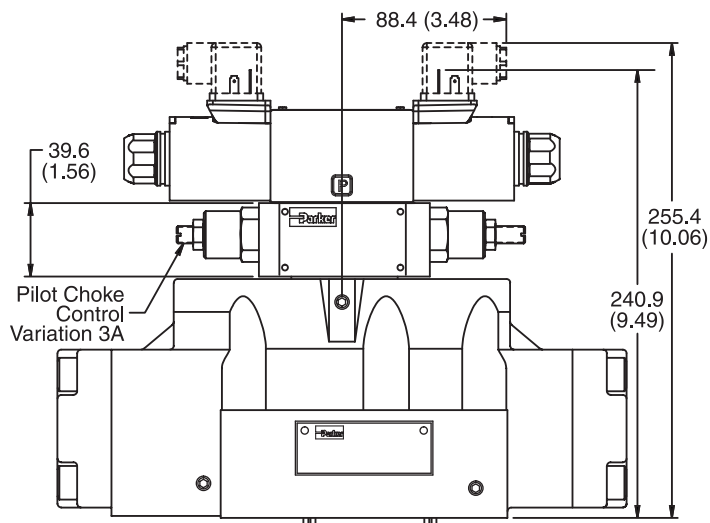

Plug-In Conduit Box, Single DC Solenoid

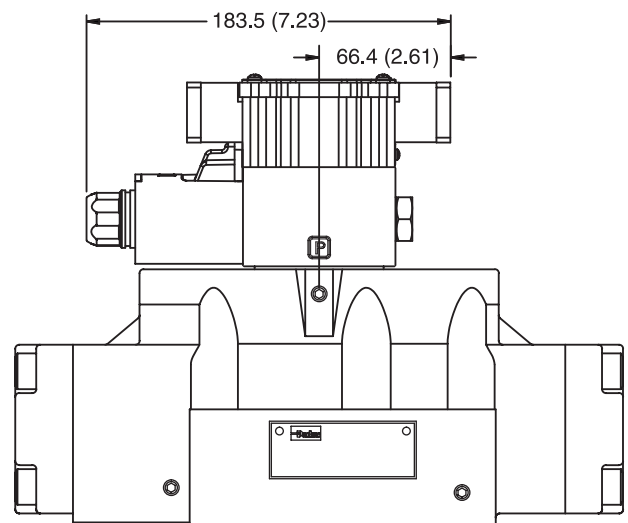

Inch equivalents for millimeter dimensions are shown in (**)

**Plug-In Conduit Box, Double AC Solenoid
with Variation I3 (Monitor Switch)**

A

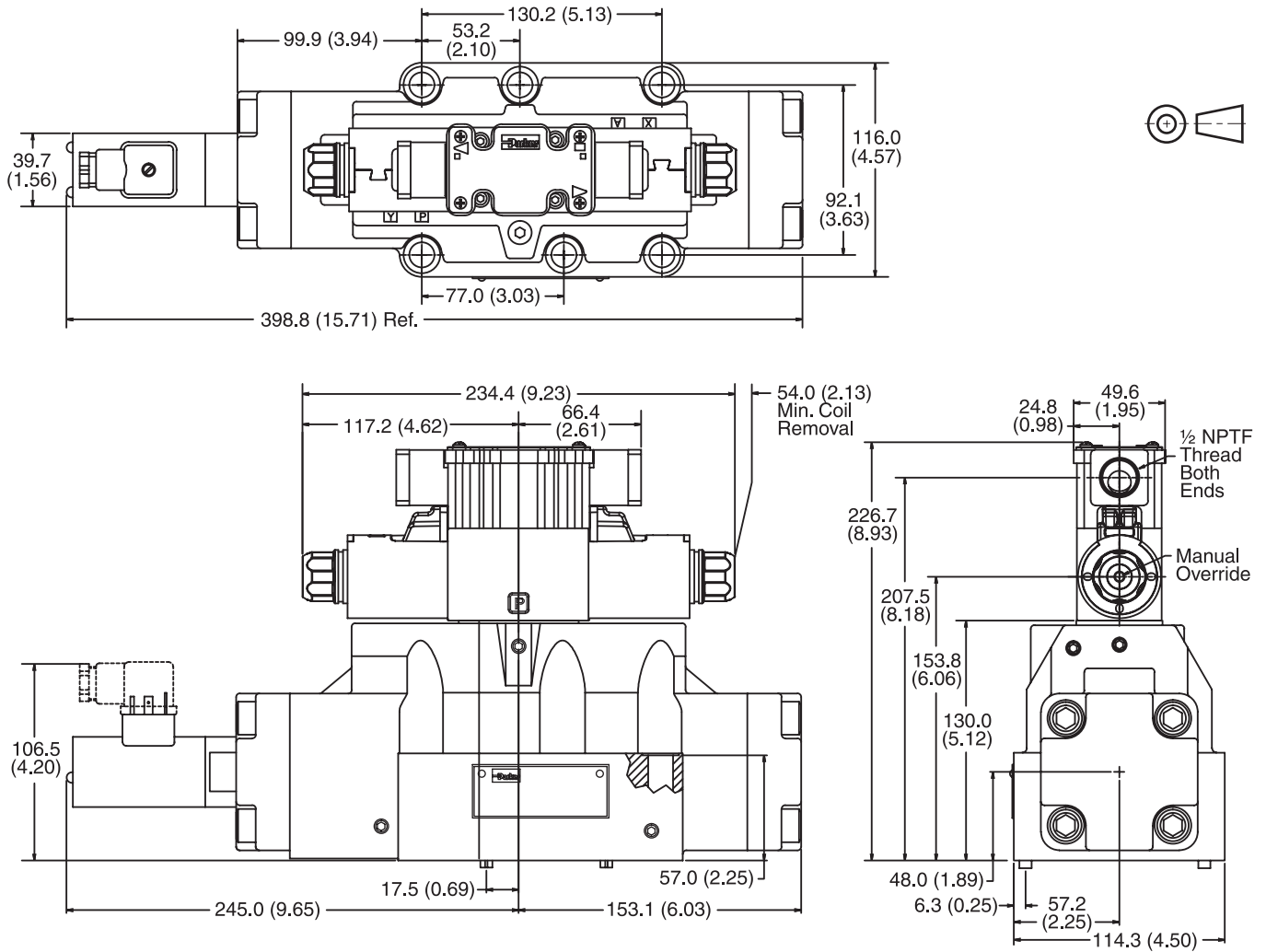

**Monitor Switch
(Variation I3 and I6)**

This feature provides for electrical confirmation of the spool shift. This can be used in safety circuits, to assure proper sequencing, etc.

Switch Data

Pin 1 and Pin 3 have outputs equal to the input. When the monitor switch has the output to Pin 1, Pin 3 will have an output of zero, and vice-versa. When the valve is switched, Pin 1 and Pin 3 will switch outputs.

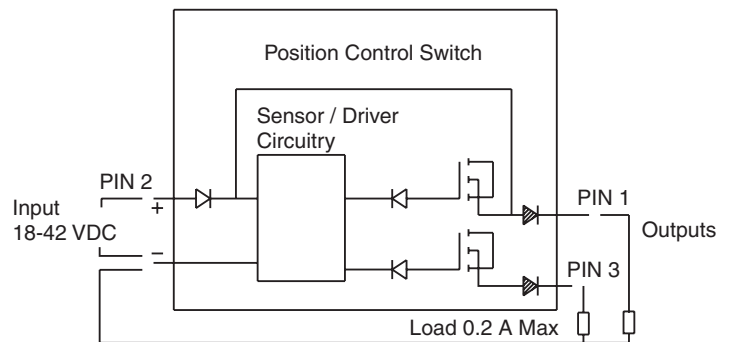



Manaplug (Options 56 & 1C)

- Interface – Brad Harrison Plug
- 3-Pin for Single Solenoid
 - 5-Pin for Double Solenoid

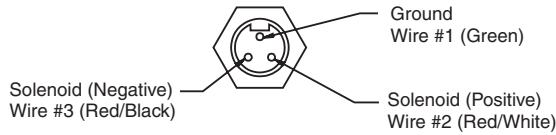

3-Pin Manaplug (Mini) with Lights

Single Solenoid Valves – Installed Opposite Side of Solenoid

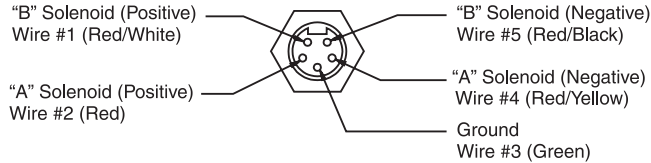

5-Pin Manaplug (Mini) with Lights

Single Solenoid Valves – Installed Opposite Side of Solenoid
 Double Solenoid Valves – Installed Over "A" Solenoid
 ("A" and "B" Solenoids Reversed for #8 and #9 Spools)

Micro Connector Options (7B & 1D)

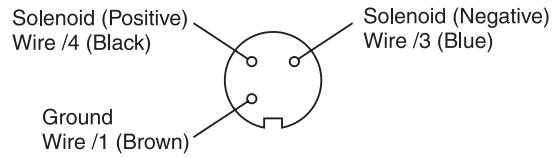

3-Pin Manaplug (Micro) with Lights

Single Solenoid Valves – Installed Opposite Side of Solenoid

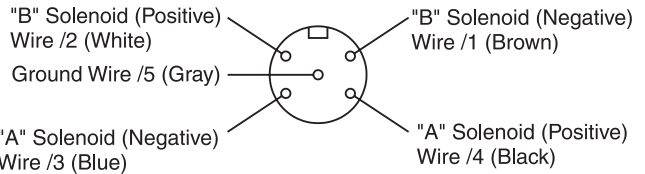

5-Pin Manaplug (Micro) with Lights

Single Solenoid Valves – Installed Opposite Side of Solenoid
 Double Solenoid Valves – Installed Over "A" Solenoid
 ("A" and "B" Solenoids Reversed for #8 and #9 Spools)

Pins are as seen on valve (male pin connectors)

Conduit Box Option C

- No Wiring Options Available

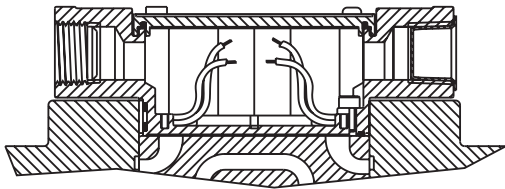

Signal Lights (Option 5) — Plug-in Only

- LED Interface
- Meets Nema 4/IP67

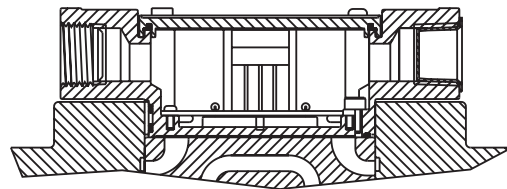

Hirschmann Plug with Lights (Option P5)
ISO 4400/DIN 43650 Form "A"

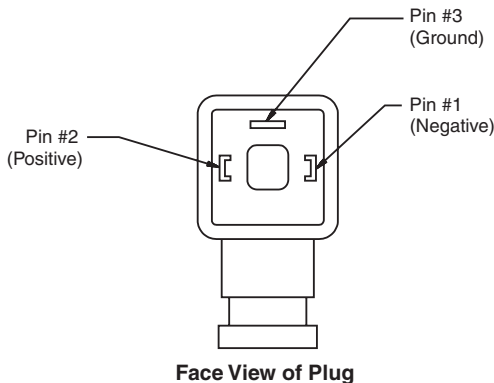

DESINA Connector (Option D)
M12 pin assignment
Standard

- 1 = Not used
- 2 = Not used
- 3 = 0V
- 4 = Signal (24 V)
- 5 = Earth Ground

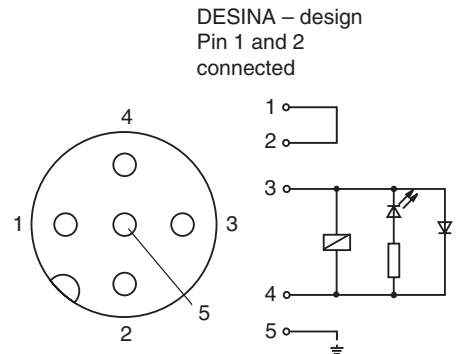

Pins are as seen on valve (male pin connectors)